

AMPACT Tool

1

FEATURES

- Conductor applications imprinted on tap packages
- Packages and labels color coded to match taps to tools and cartridges

APPLICATIONS

- Installs and removes taps even in confined spaces

BENEFITS

- Adaptable for standard hot-stick use
- Lightweight powder-actuated tools require minimum operator effort



PRODUCT SELECTION INFORMATION

Catalog Number	Product Description	Connects
69437	Small AMPACT Tool (For Red-, White-, and Blue-coded taps)	Aluminum Wire Combinations: #8 – 350 kcmil
69611	Large AMPACT Tool (For Yellow-coded taps only)	Aluminum Wire Combinations: 336.4 – 1192.5, up to 3000 MCM AMPACT EL tap connectors

USING THE AMPACT TOOL WITH THE HOT STICK

- Position "piggyback" clamp onto wire.
"C" member hooked onto the wire

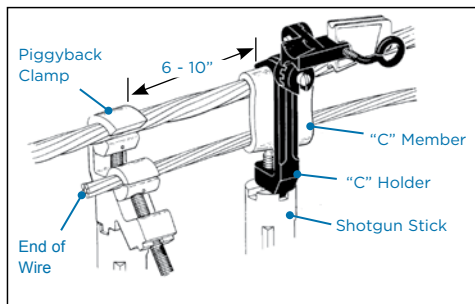

- Wedge is placed in "C" member.

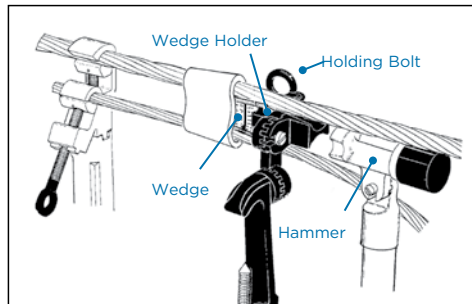

- AMPACT tool clamped over the tap.

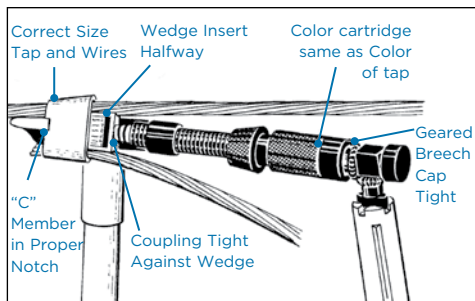

- Tap is completed by hammer blow to end of tool.

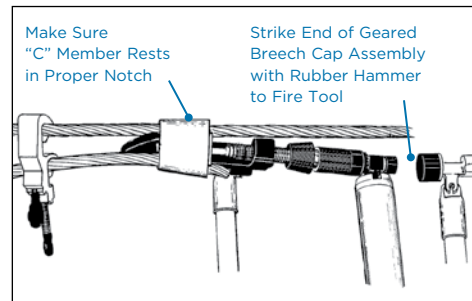

69633-2



314196-1, 5-304668-3



308967-1



47667-8



69612

REPLACEMENT PARTS

Catalog Number	Description
69633-2	Large Tool Head
47667-8	Small Tool Head
69612	Universal Power Unit
308967-1	Breech Assembly
314196-1	Breech Cap Assembly (3-Pc)
5-304668-3	Retaining Spring

AMPACT EZLoad

FEATURES

- The AMPACT EZLoad tool is a precision designed, powder actuated tool that is robust yet lightweight.
- The tool is designed with a lock and load approach.
- The cartridges are molded of weatherproof polyethylene and packed with propellant and primer.
- The color of the cartridge indicates the strength of the powder charge and corresponds to the color-code of tap sizes with which they are used.

APPLICATIONS

- AMPACT cartridges are color-coded (red etc.) and designed specifically for use in the AMPACT EZLoad tools to install AMPACT taps

BENEFITS

- ♦ This all in one design hinges on the power unit and is easily opened and closed to replace the cartridges.
- ♦ AMPACT tools are engaged by firing a special powder loaded cartridge within the tool which reduces the time and effort required to tap a power line.
- ♦ The compact tools are manufactured in high-grade steel to precise tolerances and are available in two sizes: large head and small head. The same interchangeable power unit is used in both tools.

PRODUCT SELECTION INFORMATION



Catalog Number	Description
1043413-1	AMPACT EZLoad Small tool
1443414-1	AMPACT ZLoad Large tool
1443413-2	AMPACT ZLoad Power k Adapter
1443514-1	AMPACT ZLoad Hot-Stick Adapter Kit (includes Piercer pin guide and cover)
1443470-1	AMPACT ZLoad Hot-Stick Adapter with Power Unit
1443442-1	AMPACT EZLoad Cleaning tool
1443448-1	AMPACT EZLoad Tool repair kit (included Piercer Pin guide, Piercer pin and grub screw)
69610-2	Hot-stick Kit for EZLoad tool
1443412-1	AMPACT EZLoad Power Unit

Cartridges



PRODUCT SELECTION INFORMATION

Catalog Number	Description
69338-5	White
69338-2	Red
69338-1	Blue
69338-4	Yellow

Inhibitor Compound and NEMA Interface Hinge

Inhibitor Can



NEMA Hinge



Inhibitor Bottle



PRODUCT SELECTION INFORMATION

Catalog Number	Description
80665-3	8 oz. (236 ml) plastic bottle aluminum inhibitor compound
80665-2	1 qt (.95 litre) can aluminum inhibitor compound
561118-1*	2-Hole NEMA interface hinge to protect against corrosion between dissimilar metals
69338-4	Yellow

*IS 408-2556